

# **SMRT** AU11-HT

## TECHNICAL DATA SHEET

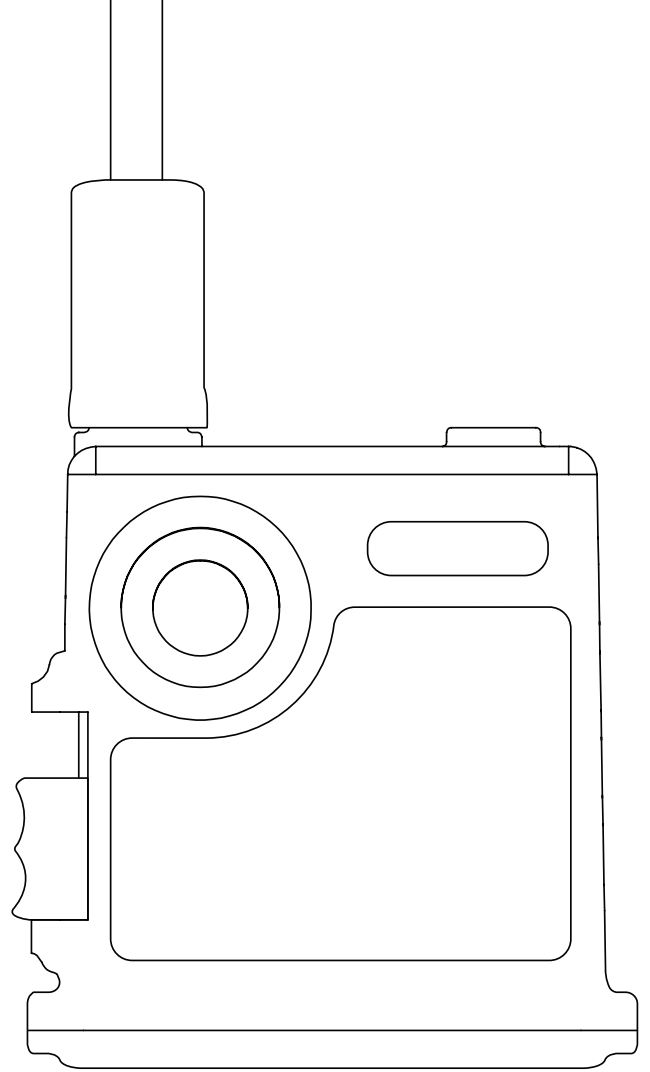

## IDENTIFICATION

PRODUCT NAME	sMRT AU11-HT
MANUFACTURERS NAME	Marine Rescue Technologies Ltd
ADDRESS	Wescom Group, Unit J1, Anlaby Trade Park, Springfield Way, Anlaby, Hull, HU10 6RJ, United Kingdom
TELEPHONE NUMBER	+44 (0)1482 679 300
EMAIL ADDRESS	smrt@wescom-group.com
DATE OF ISSUE	January 2025
ISSUE NUMBER	2
DESCRIPTION	The sMRT AU11-HT is a Man Overboard locating device. Once armed the device is designed to activate automatically in the event of a Man Overboard incident. Following activation, the sMRT AU11-HT transmits a 121.5 MHz homing signal and VHF DSC distress alert. Once a GPS position is acquired AIS location information is updated continuously.



**BATTERY SHIPPING INFORMATION: UN3091 LITHIUM METAL BATTERIES CONTAINED IN EQUIPMENT IN COMPLIANCE WITH IATA PI: 970 SECTION II.**



GENERAL	
BATTERY TYPE	6V Li-MnO <sub>2</sub>
BATTERY LIFE	Minimum of 12 hours at -20°C
BATTERY SHELF LIFE AT +20°C	>3 years
OPERATING TEMPERATURE	-20° to +55°C
STORAGE TEMPERATURE	-45° to +70°C
OPERATING HUMIDITY	To 95% non-condensing
SHOCK	20G min
VIBRATIONS	EuroCAE ED-14F
FLAMMABILITY RATING	ED 14F 26.3.3 Category C:
BUOYANCY	Buoyant (index=9%)
TRANSPORTATION	Air cargo UN 3091 not hazardous
DIMENSIONS (CASE)	80mm (H) x 95mm (W) x 35mm (D)
WEIGHT	250g
ENVIRONMENTAL	EN 303 132 V2.1.1 clause 7, IEC 60945:2002
ENVIRONMENTAL RATING	IP68 up to 10 metres depth
MOUNTING OPTIONS	Designed to integrate with a SOLAS approved life jacket
SELF ID	ITU-R M.585 compliant factory programmed freeform Maritime Identity with 972 prefix
COMPASS SAFE DISTANCE	30cm (for <1° deflection)
ALERTING RADIUS	Up to 5NM (depending on height of antenna)*
ATEX CLASSIFICATION	Ex ic T4 Gc
TRANSMITTER PACKAGES	
AIR BAND FREQUENCIES	121.500 MHz, 121.650 MHz
AIS Tx POWER OUTPUT	Nominal 1W EIRP
VHF TRANSMISSION FREQUENCIES	VHF DSC Channel 70: 156.525 MHz, AIS Channel 1: 161.975 MHz, AIS Channel 2: 162.025 MHz
VHF DSC Tx POWER OUTPUT	Nominal 1W EIRP
SIGNALLING TYPE	AIS and VHF-DSC
DISTRESS MODULATION	AM compliant to ITU-R M.690-2 (2012)
AIR BAND POWER	100mW PERP
MARINE-BAND FREQUENCIES	161.975, 162.025 MHz (AIS1, AIS2)
MARINE-BAND POWER	Nominal 1W EIRP
VHF ANTENNA	Centre-fed dipole, comprising coaxial cable and 1/8 coil whip
GPS ANTENNA	Circular-polarised wide-angle bulb
GPS RECEIVER	
GNSS RECEIVER TYPE	GPS plus Galileo
TTFF (TIME TO FIRST FIX)	15 seconds (typical) with nominal GPS signal levels -130dBm
GNSS UPDATE RATE	Every minute

VHF DSC AND AIS ALERTS	
AIS	Within 30 seconds of GNSS position acquisition
INITIAL OPEN LOOP DSC ALERT	Within 30 seconds after activation
SUBSEQUENT OPEN LOOP DSC ALERTS	Every 5 minutes for the first 30 minutes, every 10 minutes thereafter until VHF-DSC acknowledgement or the battery expires
FIRST DSC GPS DATA ALERT SENT	Immediately after GNSS position acquired
CONTROLS AND OPERATION	
AUTOMATIC WATER ACTIVATION	After 2 seconds of water sensor immersion
MANUAL ACTIVATION	Once armed, press Activation Button
OPERATING TIME	> 12 hours continuous
STANDBY BATTERY LIFE	> 3 years
PERMANENTLY ARMED	12 hours operation if armed for 12 months
GPS POSITION UPDATE	Minimum of 6 per minute
GPS TIME TO FIRST LOCK	Typically < 1 minute under normal operating conditions
ALERT INDICATION	Audible and visible
APPROVALS	
EUROPEAN APPROVALS	EN 303 132 V2.1.1
EMC	EN 301 843-8: V1.1.1.005 EN 301 843-1: V2.3.1.0.0.8
SAFETY	EN 63268-1: 2018
ELECTRICAL SAFETY	EN 60950-1:2006
MARINE	IEC 60945: 2002
RADIO (121.5 MHz)	EN 302 961 V1.2.1
RADIO (AIS)	EN 303 098 V1.2.1
ATEX	IEC 60079-0:2012 IEC 60079-11:2012

\* Expected range derived from sea trials. Actual alerting range dependent on sea state, atmospheric conditions and height/altitude of receiving antenna.